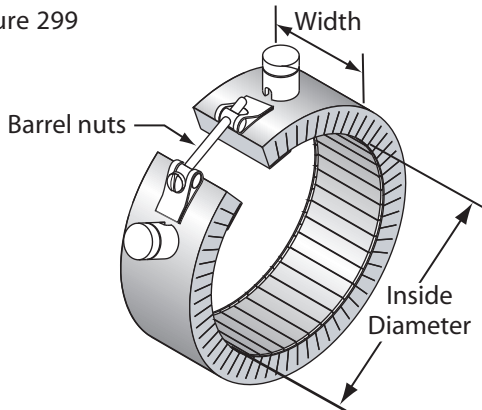


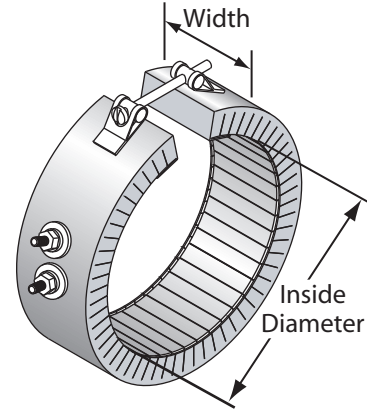


Figure 299



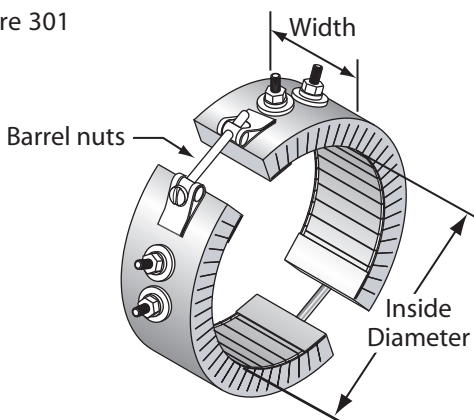
1 Piece Construction- Ceramic heaters can be opened fully. (Shown with ceramic terminal covers)

Figure 300



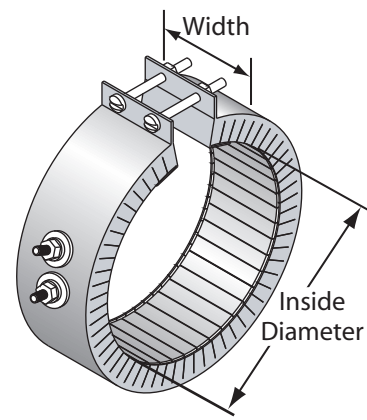
Built-in Strap- Barrel nuts provide secure and strong clamping. Also available in spring loaded designs for larger diameters

Figure 301



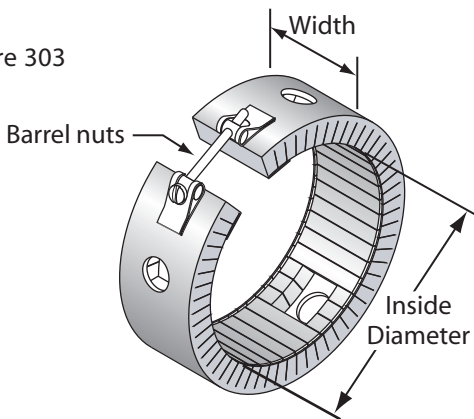
2 Piece Construction- Ease of installation in difficult locations. Recommended for diameters larger than 15".

Figure 302



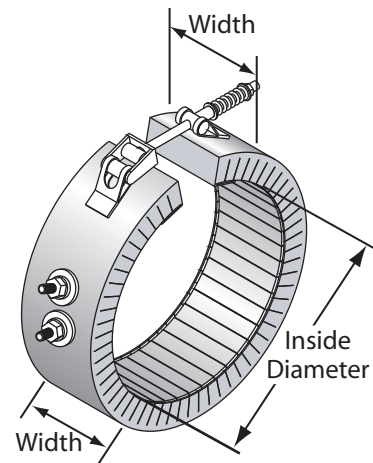
Bent up flange- Available in any termination style and is only recommended for narrower designs.

Figure 303



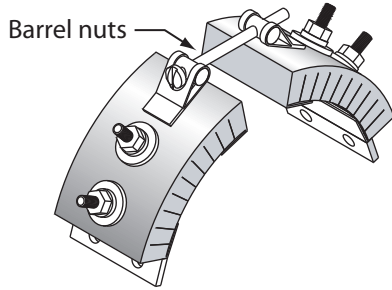
Holes and Cutouts- Allows for installation of thermocouples and transducers and give clearance for mounting bolts.

Figure 304



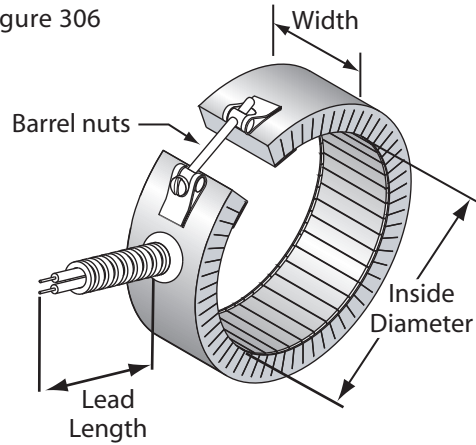
Latch and Trunion- Spring loaded clamping is recommended for larger diameter band and in applications where the heater is mounted horizontally.

Figure 305



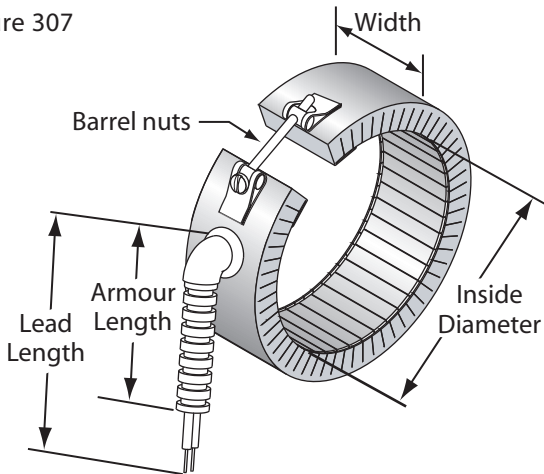
Partial Coverage Band- Used around large obstruction which holes or cut outs cannot accommodate. 2 piece construction with barrel nuts. shown. Others available

Figure 306



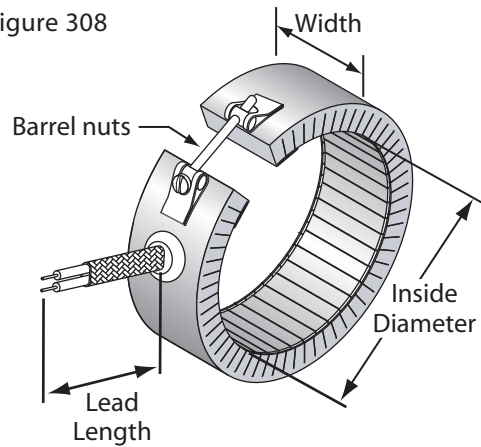
Armor cable with fiberglass leads- Specify location and length of leads at time of order.

Figure 307



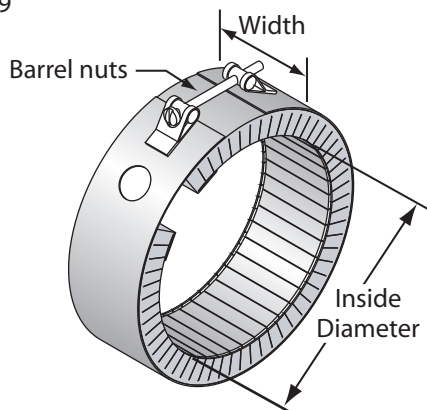
Right angle armor cable with fiberglass leads- Specify location and length of leads at time of order.

Figure 308



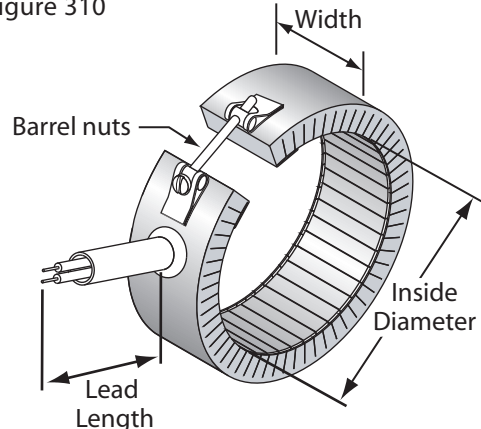
Metal braid with fiberglass leads- Specify location and length of leads at time of order.

Figure 309



Shell Overlap- The metal strap is continued over the gap and a hole is provided. This allows for thermocouple mounting without a hole in the heater.

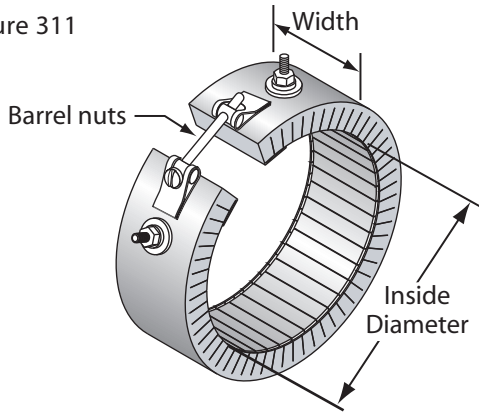
Figure 310



Fiberglass leads with protective sleeve- Specify location and length of leads at time of order.

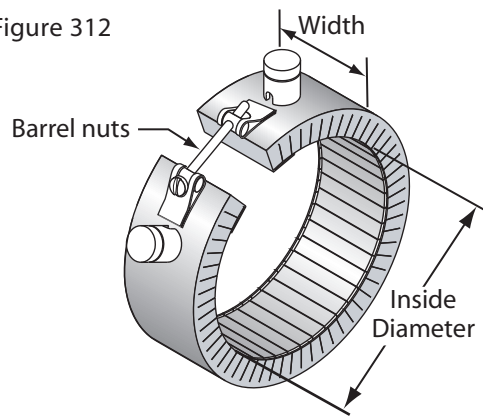


Figure 311



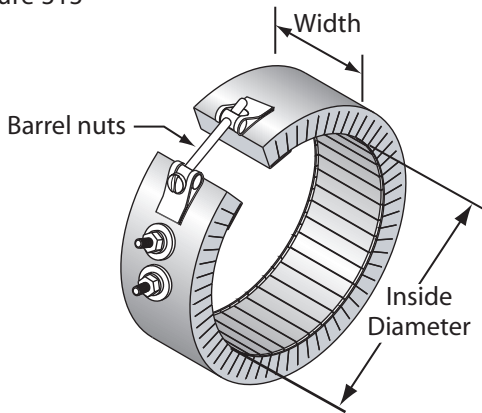
10-32 Threaded Terminals-
Minimum width required 7/8"

Figure 312



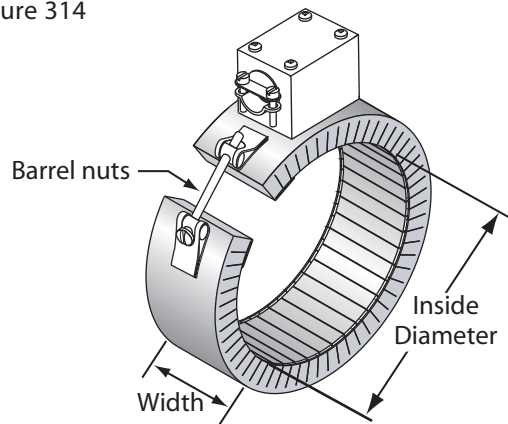
Ceramic Terminal Covers- Available on all threaded terminals. Covers available separately

Figure 313



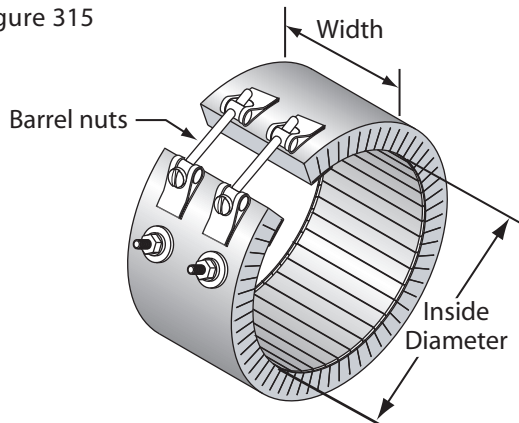
10-32 Threaded Terminals- Minimum width required 7/8"-Specify location at time of order

Figure 314



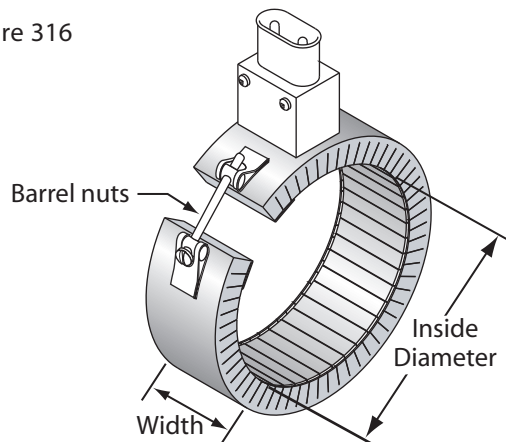
Sheet Metal Terminal Box- Available with T2 and T3 threaded terminals.

Figure 315



10-32 Threaded Terminals- Minimum width required 2.00"-Specify location at time of order

Figure 316



European Plug- Also available in 90 degree construction- Specify location at time of order